



# MIRROR COLLECTION

MIRRORS FOR EVERY INTERIOR



# 30

## years of experience in manufacturing



HLT is a **Polish company** with over **30 years of experience** in the industry, operating as a manufacturer and technology partner in the B2B sector. We support clients in the execution of both serial and custom projects, offering solutions based on our own manufacturing resources and proven processes.

Our technology ensures repeatable quality, delivery stability, and control of technical parameters. **In-house production lines** give us full control over every stage of implementation, reduce risk, shorten lead times, and allow us to maintain product consistency in long production runs.

We specialize in **mirror production** as well as **LED lighting for furniture and interiors**, including **lighting fixtures, lighting profiles** and **complete lighting systems**. In parallel, we develop **plastic profile extrusion**, enabling the design and manufacture of components tailored to specific structural and installation applications.

We also support clients in the area of technical consulting, **solution optimization**, and **preparation of products for serial production**, offering stable cooperation based on proven production capabilities.



### PRECISION EXPRESSED IN NUMBERS



**284**

EMPLOYEES



**8000**

MIRRORS PER MONTH



**26**

COUNTRIES



**10 000 m<sup>2</sup>**

SURFACE AREA

# ABOUT MIRRORS

## TECHNOLOGY AND CONSTRUCTION

We understand how critical timeliness is in trade; therefore, our **parallel production system** and local **quality control** ensure full continuity in order fulfillment. We make you independent from global logistics disruptions, ensuring **supply continuity**. In addition, comprehensive **OEM project support** – from design to branding – enables perfect alignment of the product with market requirements. You gain a unique assortment, ready for sale under your own brand, **meeting all EU standards**.

By choosing HLT mirrors, you invest in the stability and security of your business. **Our products are manufactured in Poland**, based on **proprietary technologies and certified European components**. Thanks to the use of in-house electronics and **lead-free glass**, we deliver solutions with increased durability and resistance to demanding conditions. For you, this means confidence in offering a reliable, failure-free product that reduces the risk of complaints and effectively builds end-user trust in your brand.

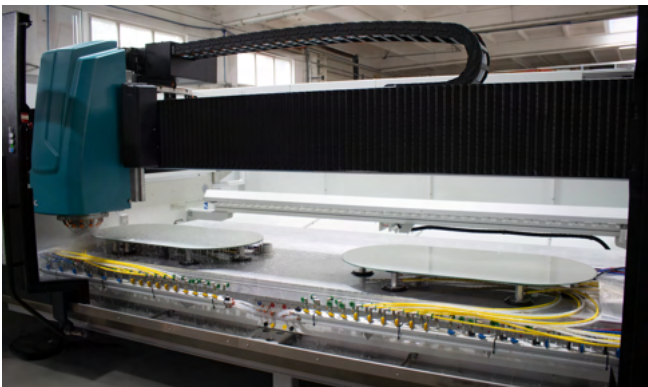

CNC



Four-edge polishing machine

## WHAT DISTINGUISHES OUR MIRRORS

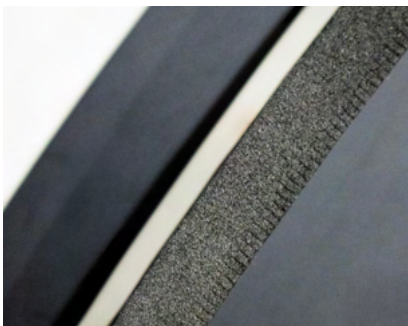

**Foam** – lightweight, water-resistant, protects the glass against stresses.

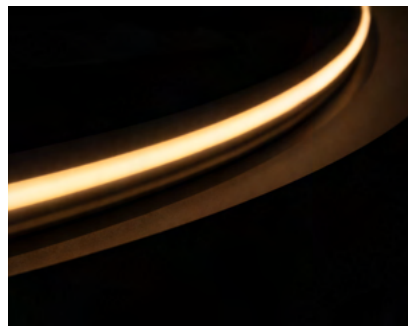

**COB LED strip in silicone** – protected against moisture, increases lighting durability.



**Light-leak-resistant backing** – uniform backlighting and clean edges.

# MIRROR CONFIGURATOR

SHAPE • SIZE • FUNCTIONS

SELECT  
SHAPE

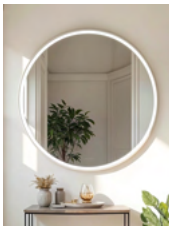

AURA



VELO



HORIZON



NEBULA



ARCADE



DIUNA

+

SELECT  
SIZE

**AURA**  
Ø 60 / Ø 80 / Ø 100 / Ø 120

**VELO**  
50x70cm/50x90cm/50x100cm

**HORIZON**  
60x70cm/80x70cm/100x70cm/  
60x60cm/80x80cm/90x90cm

**NEBULA**  
60x80cm/70x90cm/80x110cm

**ARCADE**  
50x160cm/50x170cm/60x180cm

**DIUNA**  
100x90cm/120x100cm/  
140x120cm

+

CONFIGURATION  
OPTIONS



BACKLIT



SANDBLASTING



MIRROR DEFOGGER  
PAD



SWITCH ON THE GLASS



ALUMINUM FRAME

## MIRROR CUSTOMIZATION OPTIONS

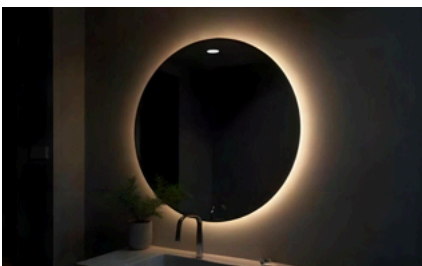

**Backlit** – subtle backlighting behind the mirror that creates a soft, atmospheric glow around the glass.



**Sandblasting** – matte, semi-transparent finish of the glass which, when backlit, creates a subtle decorative effect.



**Mirror defogger pad** – warms the mirror glass, preventing fogging and maintaining full clarity.

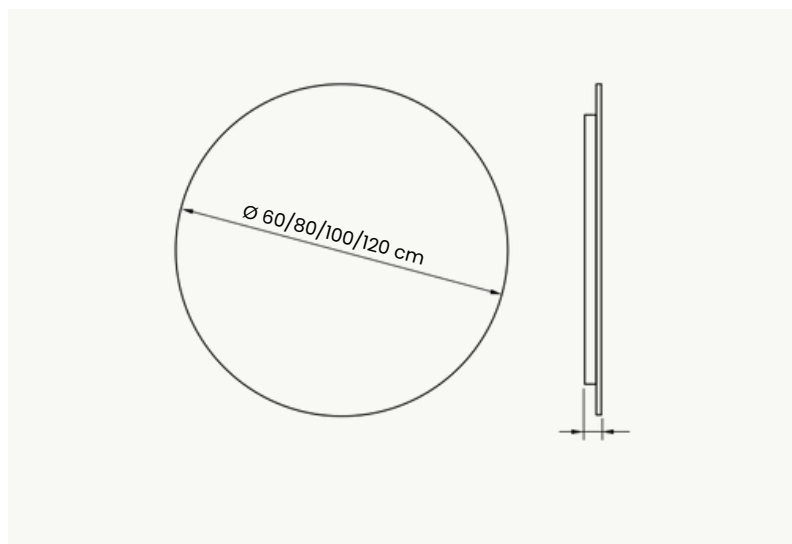

# AURA

## PREMIUM ROUND MIRRORS



The Aura model is based on a stable, lightweight construction with the option of an aluminum frame and LED backlighting. Glass of European origin ensures high reflection quality, while additional options such as sandblasting or a heating mat allow the mirror to be adapted to specific design requirements and usage conditions.



MIRROR MODEL	DIMENSIONS	AVAILABLE FRAMES	LIGHTING	MODIFICATION OPTIONS
Aura	Ø 60 cm	black / gold / none	LED COB	backlit, aluminum frame, sandblasting, mirror defogger pad, switch on the glass
	Ø 80 cm	black / gold / none	LED COB	backlit, aluminum frame, sandblasting, mirror defogger pad, switch on the glass
	Ø 100 cm	black / gold / none	LED COB	backlit, aluminum frame, sandblasting, mirror defogger pad, switch on the glass
	Ø 120 cm	black / gold / none	LED COB	backlit, aluminum frame, sandblasting, mirror defogger pad, switch on the glass

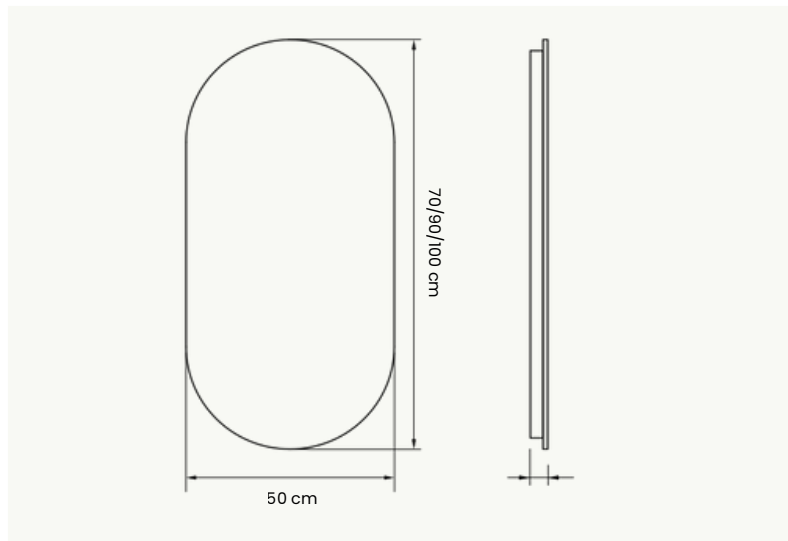

## VELO

ELONGATED MIRRORS WITH A SUBTLE FORM



The Velo mirror is a modern interpretation of the classic elongated shape, ideal for spaces with a minimalist or elegant character. Rounded edges give it lightness and subtle softness, making it well suited both for bathroom areas and for commercial, hotel, or wellness interiors.

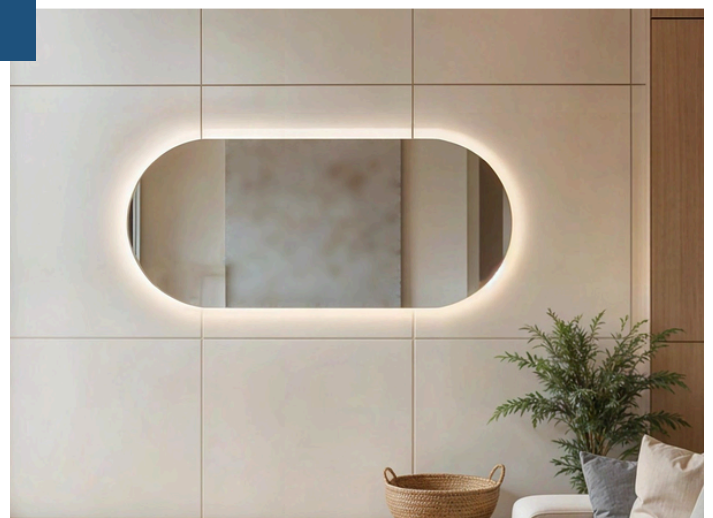

MIRROR MODEL	DIMENSIONS	AVAILABLE FRAMES	LIGHTING	MODIFICATION OPTIONS
Velo	50x70 cm	black / gold / none	LED COB	backlit, aluminum frame, sandblasting, mirror defogger pad, switch on the glass
	50x90 cm	black / gold / none	LED COB	backlit, aluminum frame, sandblasting, mirror defogger pad, switch on the glass
	50x100 cm	black / gold / none	LED COB	backlit, aluminum frame, sandblasting, mirror defogger pad, switch on the glass

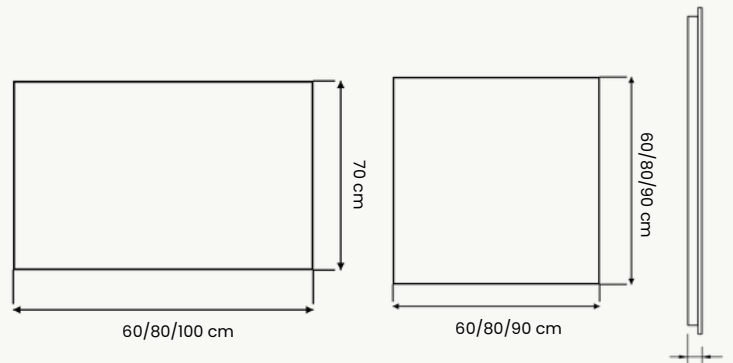

## HORIZON

RECTANGULAR MIRRORS IN A MINIMALIST DESIGN



The Horizon mirror is a solution for modern interiors where precision of workmanship and contemporary form are essential. Its rectangular or square shape and minimalist design make it a perfect match for both private bathroom architecture and commercial facilities, hotels, or wellness areas.

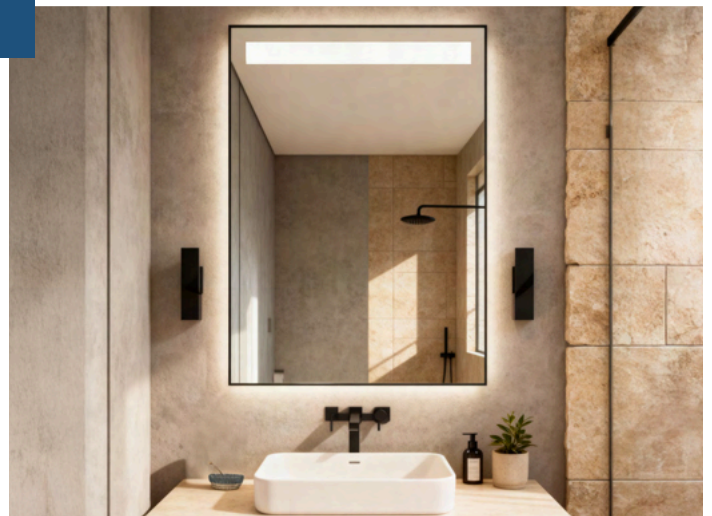

MIRROR MODEL	DIMENSIONS	AVAILABLE FRAMES	LIGHTING	MODIFICATION OPTIONS
Horizon	60x70 cm 80x70 cm 100x70 cm	black / gold / none	LED COB	backlit, aluminum frame, sandblasting, mirror defogger pad, switch on the glass
	60x60 cm 80x80 cm 90x90 cm	black / gold / none	LED COB	backlit, aluminum frame, sandblasting, mirror defogger pad, switch on the glass

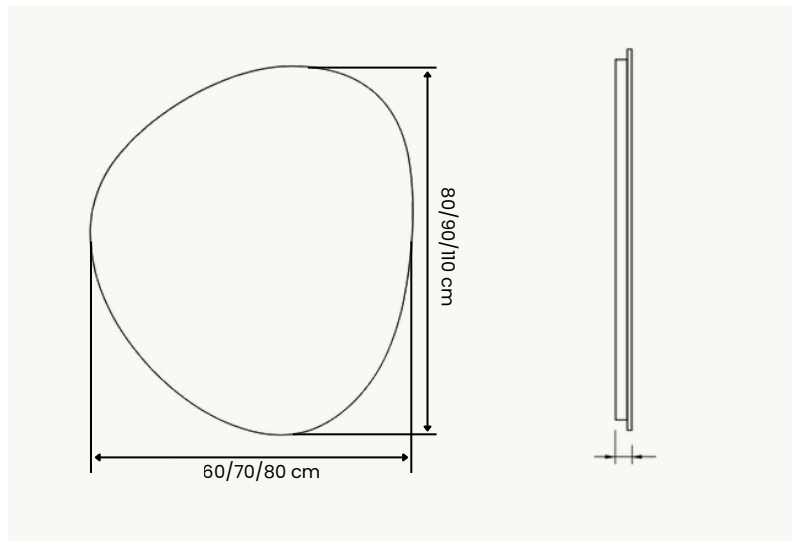

## NEBULA

ORGANIC MIRRORS FOR MODERN INTERIORS



The Nebula mirror is distinguished by an irregular, flowing line that references natural forms and gives interiors a modern, welcoming character. Thanks to its organic shape, it fits perfectly into both minimalist and more decorative designs, becoming a subtle yet distinctive accent within the arrangement.



MIRROR MODEL	DIMENSIONS	LIGHTING	MODIFICATION OPTIONS
Nebula	60x80 cm	LED COB	backlit, sandblasting, mirror defogger pad, switch on the glass
	70x90 cm	LED COB	backlit, sandblasting, mirror defogger pad, switch on the glass
	80x110 cm	LED COB	backlit, sandblasting, mirror defogger pad, switch on the glass

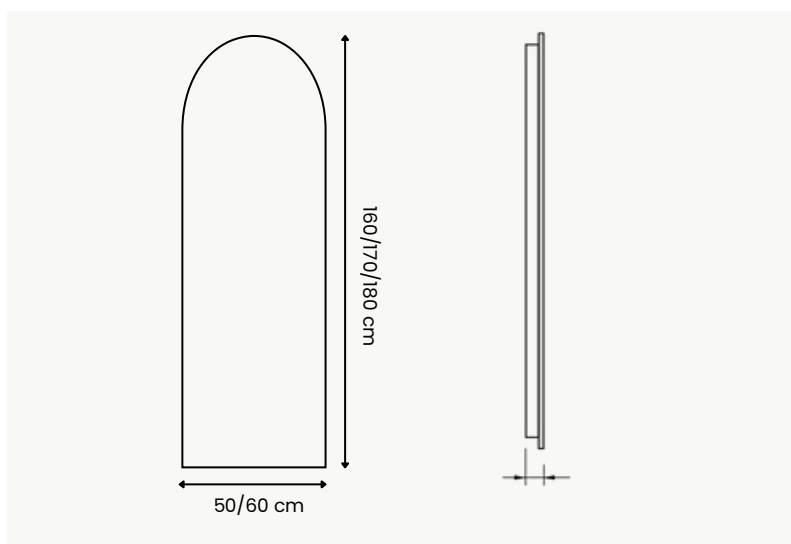

## ARCADE

A SUBTLE FORM FOR MODERN INTERIORS



The Arcade mirror draws attention with its soft, arched line, which subtly organizes the space and introduces a sense of harmony into the interior. Its slim silhouette and gently rounded top give the arrangement a feeling of lightness while emphasizing the contemporary character of the space. Arcade works perfectly with bright interiors, natural light and a calm color palette.



MIRROR MODEL	DIMENSIONS	AVAILABLE FRAMES	LIGHTING	MODIFICATION OPTIONS
Arcade	50x160 cm	black / gold / none	LED COB	backlit, aluminum frame, sandblasting, mirror defogger pad, switch on the glass
	50x170 cm	black / gold / none	LED COB	backlit, aluminum frame, sandblasting, mirror defogger pad, switch on the glass
	60x180 cm	black / gold / none	LED COB	backlit, aluminum frame, sandblasting, mirror defogger pad, switch on the glass

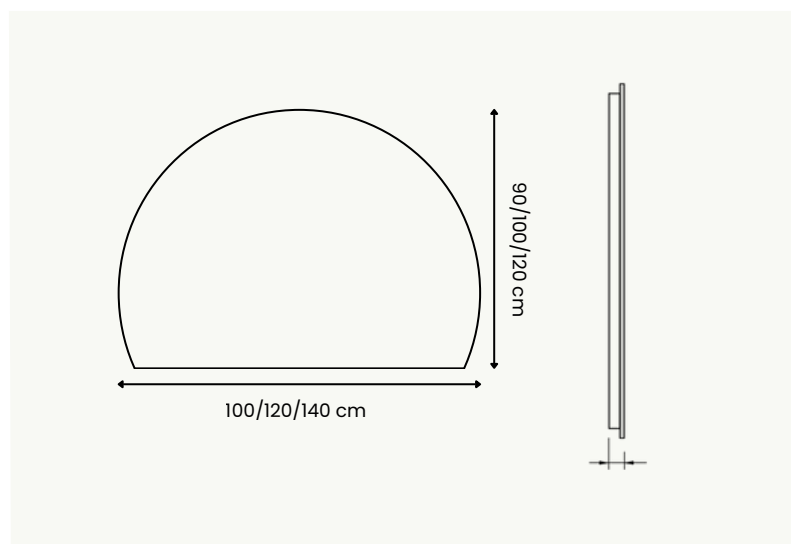

## DIUNA

A CLEAN FORM WITH A DISTINCT CUT



The DIUNA mirror is distinguished by a minimalist circular form subtly interrupted by a straight line. The delicate cut gives the design a modern, architectural character while maintaining visual lightness and harmony. Thanks to its balanced proportions, DIUNA fits perfectly into calm, carefully refined interior arrangements.

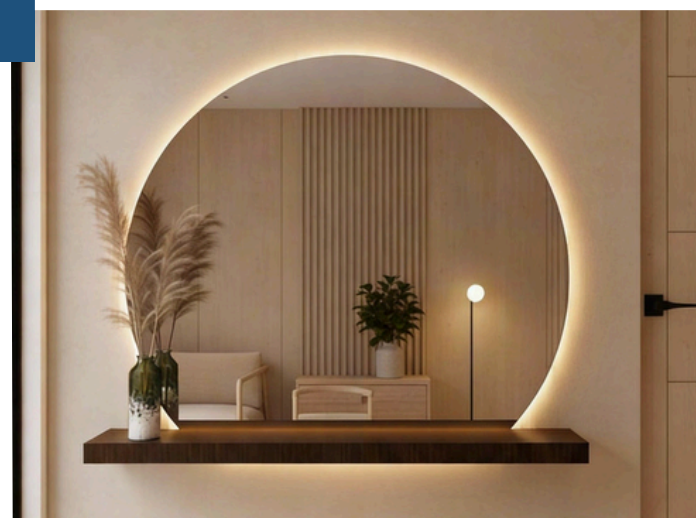

MIRROR MODEL	WYMIARY	AVAILABLE FRAMES	LIGHTING	MODIFICATION OPTIONS
Diuna	100x90 cm	black / gold / none	LED COB	backlit, aluminum frame, sandblasting, mirror defogger pad, switch on the glass
	120x100 cm	black / gold / none	LED COB	backlit, aluminum frame, sandblasting, mirror defogger pad, switch on the glass
	140x120 cm	black / gold / none	LED COB	backlit, aluminum frame, sandblasting, mirror defogger pad, switch on the glass

## SAFE PACKAGING

We have developed our own packaging standards that ensure the protection of mirrors during transport and storage. Every detail has been selected with precision to guarantee delivery reliability.

The mirror is protected with a layer of nonwoven fabric, which safeguards the glass surface against scratches and reduces direct contact with the packaging. A rigid cardboard construction stabilizes the product and protects it from mechanical damage during storage and transport.

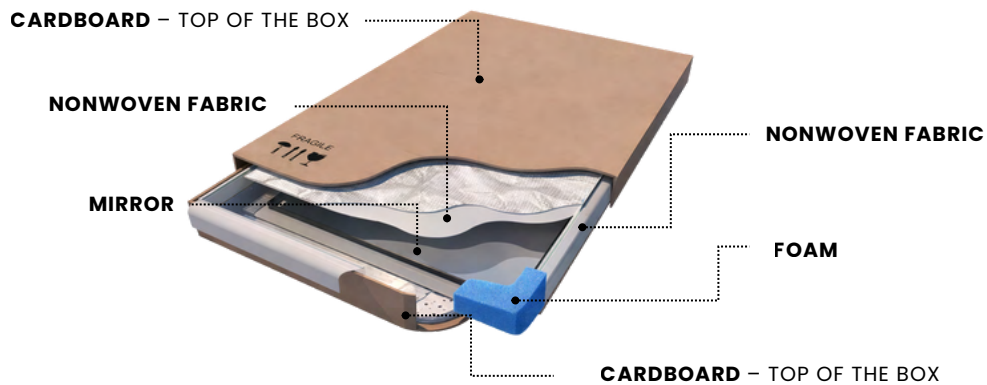

Depending on the model and size of the mirror, we use individual or collective packaging.



We cooperate with trusted logistics partners operating both domestically and internationally.



Each mirror is packed by hand and undergoes quality control prior to shipment.



Ready for dispatch – mirrors prepared for secure shipment of individual orders and further distribution.

This catalogue does not constitute an offer within the meaning of the law and is published for informational purposes only.

HLT Sp. z o.o. reserves the right to make technical changes to the specifications of the presented products.

Product photos and drawings included in the catalogue are published for illustrative and informational purposes only and may slightly differ from the products available for sale.

HLT Sp. z o.o. reserves the right to modify the catalogue offer.

Current information is available at the Sales Office or on the website [www.hlt.pl](http://www.hlt.pl).

All products of HLT Sp. z o.o. comply with:



HLT Sp. z o.o., ul. Kolejowa 5, 48-340 Głucholązy, POLAND  
NIP: 7551303668, REGON: 531160066, KRS: 0000080430 District Court in Opole.  
Share capital: PLN 277,536.00, BDO: 000009308



ul. Kolejowa 5  
48-340 Głuchołazy  
+48 77 409 25 70  
[hlt@hlt.pl](mailto:hlt@hlt.pl)  
[www.hlt.pl](http://www.hlt.pl)

